

DemirDöküm

Nitromix P24 & P28 & P35

Εγκατάσταση και Service



Λέβητας συμπύκνωσης υψηλής απόδοσης

Περιεχόμενα

1. Γενικά.....	
1.1. Εντυπα προϊόντος.....	5
1.2. Εγγύηση.....	
2. Περιγραφή.....	
2.1. Εξαρτήματα ασφαλείας	
2.1.1. Ασφάλεια υπερθέρμανσης	5
2.1.2. Βαλβίδα ασφαλείας	
2.1.3. Προστασία από παγετό.....	
2.1.4. Πάγωμα στον σωλήνα συμπύκνωσης.....	
2.2. Κατηγορία αερίου	
2.3. Υδραυλικό κύκλωμα.....	
3.Τεχνικά στοιχεία	7
4 Διαστάσεις.....	8
5 Τύποι εγκατάστασης.	9
6. Προσπέλαση στο εσωτερικό του μηχανήματος.....	10
7. Σύνδεση παροχής ρεύματος.....	
8. Καλώδιο ηλεκτρικής παροχής.....	
9. Πρόσθετες συνδέσεις	10
10. Ηλεκτρικό διάγραμμα	Σφάλμα! Δεν έχει οριστεί σελιδοδείκτης.
11. Διαδικασία έναυσης του λέβητα	11
12. Πίνακας ελέγχου	Σφάλμα! Δεν έχει οριστεί σελιδοδείκτης.
13. Λειτουργία τον Χειμώνα	Σφάλμα! Δεν έχει οριστεί σελιδοδείκτης.
16. Ρύθμιση παραμέτρων	Σφάλμα! Δεν έχει οριστεί σελιδοδείκτης.
15. Μνήμη σφαλμάτων	16
15.1. Κωδικοί σφαλμάτων.....	17
15.4. Functional flow diagram.....	18
15.4.1. Central Heating.....	18
15.4.2. Domestic Hot Water	19
16. Gas conversion adjustments.....	19
17. Draining	20
17.1. Heating circuit	20
17.2. Domestic Hot water circuit.....	20
18. Servicing	20
18.1. Annual Maintenance	20
18.1.1. Verification of components.....	20
18.1.2. Other checks.....	21
18.1.3. Cleaning of the components	21
18.1.4. Corrosion and anti-sludge protection	21
18.2. Combustion check and Setting the air gas ratio valve	21
18.2.1. Competency to carry out the check of combustion performance	21
18.2.2. Preliminaries.....	21
18.2.3. Maximum rate check and adjustment	22
18.2.4. Gas Rate Check	22
18.2.5. Completion	22
18.3. Servicing	22
18.4. Silencer	22
18.5. Expansion vessel.....	23
18.6. Plate heat exchanger filter	23
18.7. Heating filter.....	23
18.8. Condensate Trap	24
18.9. Combustion block.....	24
18.9.1. Spark electrode.....	25

18.9.2.	Dismantling the burner	
18.9.3.	Cleaning the heat exchanger	26
18.9.4.	Burner control	26
18.9.5.	Re-assembling the burner group	26
18.9.6.	Service completion	26
19.	Replacement of Parts	26
19.1.	General	27
19.2.	Boiler Access	27
19.3.	Viewing window	27
19.4.	Expansion vessel	27
19.5.	Hydraulic block	29
19.5.1.	Pump (head only)	30
19.5.2.	Safety discharge valve	30
19.5.3.	Automatic air vent	30
19.5.4.	Low water pressure sensor	30
19.5.5.	Flow sensor and impeller	30
19.5.6.	Bypass	30
19.5.7.	Three way valve motor	30
19.5.8.	Plate-to-plate heat exchanger	31
19.6.	Combustion block	31
19.6.1.	Spark electrode	33
19.6.2.	Igniter unit	33
19.6.3.	Removing the combustion /burner door assembly	33
19.6.4.	Burner	33
19.6.5.	Heat exchanger	33
19.6.6.	Re-assembling the burner group	34
19.6.7.	Heating Flow Thermistor	34
19.6.8.	Heating Return Thermistor	34
19.6.9.	Gas valve	34
19.6.10.	Fan	34
19.7.	Condensate trap	34
19.8.	PCB	35
19.8.1.	Main PCB	35
19.8.2.	2A Fuse Rating	35
19.8.3.	User interface PCB	35
19.8.4.	Mains supply cable	35
20.	Spare parts	36

1. Γενικά

1.1. Εντυπα προϊόντος

Οι οδηγίες αποτελούν αναπόσπαστο μέρος της συσκευής και πρέπει να παραδοθεί στον χρήστη μετά την ολοκλήρωση της εγκατάστασης, προκειμένου να συμμορφωθούν με την ισχύουσα ρύθμιση.

• Διαβάστε προσεκτικά το εγχειρίδιο, για να κατανοήσουν όλες τις πληροφορίες που επιτρέπουν την ασφαλή εγκατάσταση, χρήση και συντήρηση. Δεν φέρουμε καμία ευθύνη σε περίπτωση ζημίας για τη μη συμμόρφωση με τις οδηγίες του παρόντος εγχειριδίου οδηγιών. Οι οδηγίες αυτές περιλαμβάνουν, Εγκατάσταση, Συντήρηση, βλαβών, Αντικατάσταση εξαρτημάτων και ανταλλακτικών. Οι οδηγίες αποτελούν αναπόσπαστο μέρος της συσκευής και πρέπει να συμμορφωθεί με το τρέχον τεύχος της ασφάλειας αερίου (εγκατάσταση και χρήση) των κανονισμών, και να παραδοθούν στον χρήστη με την ολοκλήρωση της εγκατάστασης.

1.2. Εγγύηση

Σας ευχαριστούμε για την εγκατάσταση αυτής της νέας συσκευής στο σπίτι σας. Αυτές οι συσκευές που κατασκευάζονται με τα πολύ υψηλότερα πρότυπα έτσι είμαστε στην ευχάριστη θέση να προσφέρουμε στους πελάτες μας μια συνολική εγγύηση. Αυτό το προϊόν είναι εγγυημένο για 24 μήνες από την ημερομηνία εγκατάστασης ή οποιαδήποτε είναι η μικρότερη, για ανταλλακτικά. Το δεύτερο έτος της εγγύησης μέρη, από τις αρχές του 13ου μήνα μετά την εγκατάσταση ή κατασκευή, εξαρτάται από το λέβητα αφού συντηρήθηκε από αρμόδιο πρόσωπο, σύμφωνα με τις συστάσεις του κατασκευαστή. Σας συνιστούμε την τακτική συντήρηση της συσκευής αερίου σας.

2. Περιγραφή

2.1. Εξαρτήματα ασφαλείας

2.1.1. Ασφάλεια υπερθέρμανσης

Η συσκευή έχει σχεδιαστεί για να αναγνωρίζει την υπερθέρμανση και θα σβήσει πριν συμβεί αυτό.

2.1.2. Βαλβίδα ασφαλείας

Μια βαλβίδα ασφαλείας και εκκένωσης έχουν τοποθετηθεί στο λέβητα. Η βαλβίδα δεν πρέπει να

αγγίζεται.

• Η βαλβίδα ασφαλείας θέρμανσης ανοίγει όταν η πίεση στο κύκλωμα θέρμανσης υπερβαίνει τα 3 bar.

2.1.3. Προστασία από παγετό

Η συσκευή διαθέτει ενσωματωμένο στη συσκευή αντιπαγετική προστασία που προστατεύει το λέβητα από το πάγωμα. Με τις προμήθεια φυσικού αερίου και ηλεκτρικής ΟΝ και ανεξάρτητα από οποιαδήποτε ρύθμιση του θερμοστάτη δωματίου, η συσκευή αντιπαγετικής προστασίας θα λειτουργήσει την αντλία όταν η θερμοκρασία του νερού του λέβητα πέσει κάτω από 8 ° C.

Ένα χρονόμετρο που χρησιμοποιείται, έτσι ώστε η θερμοκρασία μπορεί να ελέγχονται περιοδικά. Μετά από 10 λεπτά η αντλία θα σταματήσει όταν η θερμοκρασία είναι υψηλότερη από 10 ° C ή έχει ήδη φθάσει τους 35 ° C.

Ο καυστήρας θα ενεργοποιείται όταν η θερμοκρασία του λέβητα δεν φθάνει από 10 ° C μετά από 30 λεπτά ή ανά πάσα στιγμή αν η θερμοκρασία πέσει στους 5 ° C. Ο καυστήρας θα σβήσει όταν η θερμοκρασία φτάνει τους 35 ° C. Το σύστημα προστασίας είναι ενεργό όταν η συσκευή είναι ενεργοποιημένη.

Οι έλεγχοι του λέβητα δεν μπορεί να διασφαλίσει ότι η εγκατάσταση είναι πλήρως προστατευμένες από τον παγετό. Οι εμφανείς σωληνώσεις πρέπει να προστατεύονται επαρκώς και ιδιαίτερη προσοχή πρέπει να δοθεί στην αποχέτευση συμπυκνωμάτων.

2.1.4. Πάγωμα στον σωλήνα συμπύκνωσης

Κατά τη διάρκεια του ψύχους μπορεί να σχηματιστεί πάγος στον αγωγό συμπύκνωσης. Σε αυτήν την περίπτωση, μια συσκευή ασφαλείας κλείνει την συσκευή.

2.2. Κατηγορία αερίου

Ο λέβητας είναι για χρήση μόνο για G20, αλλά μπορεί να μετατραπεί για χρήση σε G31.

2.3. Υδραυλικό κύκλωμα

1. Βάνα αερίου
 2. Βάνα κυκλώματος θέρμανσης
 3. Βαλβίδα ασφαλείας
 4. N/A
 5. Αισθητήρας Z.N.X.
 6. Εναλλάκτης Z.N.X.
 7. Διαφορική βαλβίδα
 8. Αισθητήρας θέρμανσης επιστροφής
 9. Σιφώνι συμπύκνωσης
 10. Ηλεκτρόδιο ανάφλεξης και ιονισμού
 11. Καυστήρας
 12. Εναλλάκτης θέρμανσης
 13. Θερμοστάτης ασφαλείας
 14. Εξοδος καυσαερίων
 15. Είσοδος και σιγαστήρα αέρα
 16. Δοχείο διαστολής
 17. Ανεμιστήρας
 18. Βαλβίδες αερίου
 19. Μετασχηματιστής ανάφλεξης
 20. Αισθητήρας θέρμανσης προσαγωγή
 21. Αυτόματο εξαεριστικό
 22. Κυκλοφορητής
 23. Τρίοδη βαλβίδα
 24. Αισθητήρας πίεσης
 25. Βάνα κυκλώματος θέρμανσης
 26. Βάνα εισόδου ύδρευσης
 27. Βάνα Z.N.X.
- A. Προσαγωγή
B. Ζεστό νερό
C. Εξοδος βαλβίδας ασφαλείας
D. Αέριο
E. Νερό ύδρευσης
F. Επιστροφή
G. Εξοδος συμπυκνωμάτων

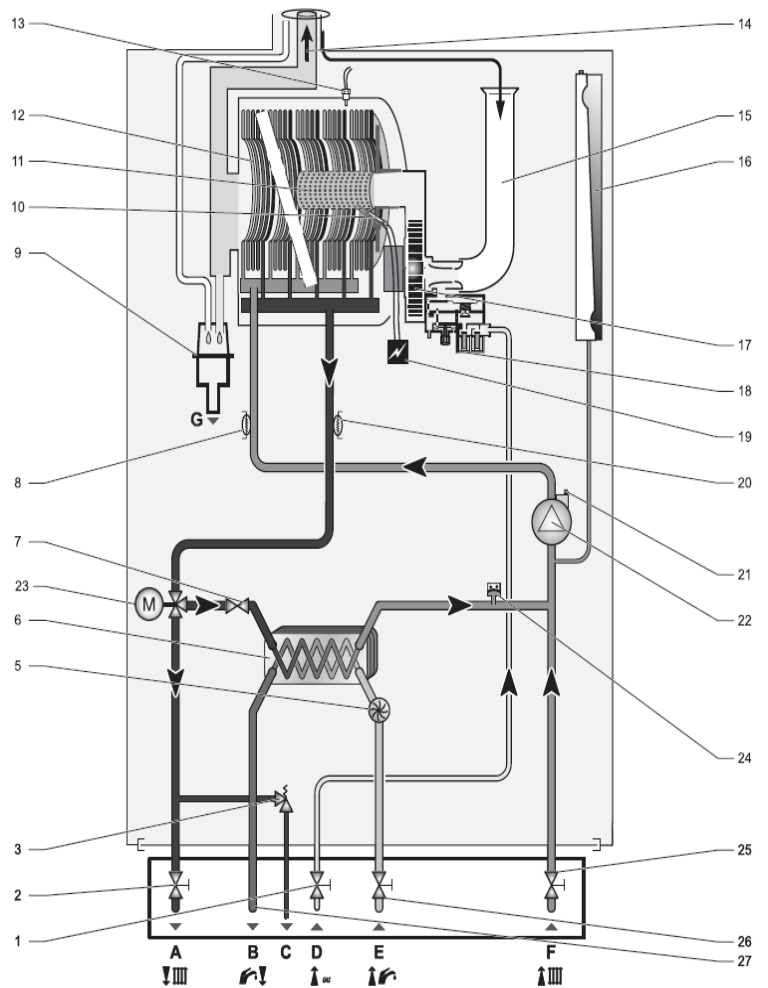

3. Τεχνικά στοιχεία

	P24	P28	P35
Κατηγορία αερίου (EN 437)	II2H3+	II2H3P	II2H3P
Διαστάσεις (H x W x D) [mm]	740 x 425 x 310	740 x 425 x 340	740 x 425 x 340
Βάρος (χωρίς συσκευασία) [kg]	32,3	34	35.5
Μέγιστη ηλεκτρική ισχύς [W]	130	130	150
Κατηγορία ασφαλείας	IP X4D	IP X4D	IP X4D
Παροχή ρεύματος [V/Hz]	230 V / 50 Hz	230 V / 50 Hz	230 V / 50 Hz
Πίεση αερίου [mbar]	G20: 20 mbar G31: 37 mbar	G20: 20 mbar G31: 37 mbar	G20: 20 mbar G31: 37 mbar
Μέγιστη ισχύς (Hi) [kW]	23	27	35
Ελάχιστη ισχύς 80°/60°C (Pmin) [kW]	5.8	7.8	6.5
Μέγιστη ισχύς 80°/60°C (Pmax) [kW]	22.4	26.3	34.1
Ελάχιστη ισχύς 50°/30°C (Pmin) [kW]	6.5	8.7	7.2
Μέγιστη ισχύς 50°/30°C (Pmax) [kW]	24.7	29	37.8
Απόδοση [%]	80/60: 97,5 50/30: 107,5	80/60: 97,5 50/30: 107,5	80/60: 97,5 50/30: 107
30%-Απόδοση [%]	107,9	108,9	109
Κατηγορία κατά NOx [mg/kWh] (BS EN 483)	Class 5	Class 5	Class 5
Θερμοκρασία νερού G20 [°C]	71,9 / 64,6	74,5 / 64,3	75,2 / 65,4
Τύπος εγκατάστασης	C13, C33, C43, C53, C83, B23, B23P, B23	C13, C33, C43, C53, C83, B23, B23P, B23	C13, C33, C43, C53, C83, B23, B23P, B23
Ρύθμιση θερμοκρασίας θέρμανσης [°C] 80°/60°C	10-75	10-75	10-75
Ρύθμιση θερμοκρασίας Z.N.X. [°C]	38-60	38-60	38-60
Πίεση [bar]	3	3	3
Χωριτικότητα Δ.Δ [l]	7	7	8
Ελάχιστη πίεση ύδρευσης [bar]	0,8	0,8	0,8
Ελάχιστη παροχή νερού [l/min]	1.5	1.5	1.5
Παροχή Z.N.X. (ΔT=30 K) [l/min]	11	12,5	15

4. Διαστάσεις

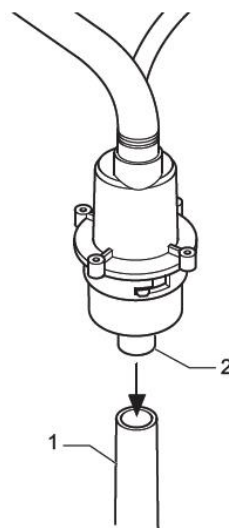
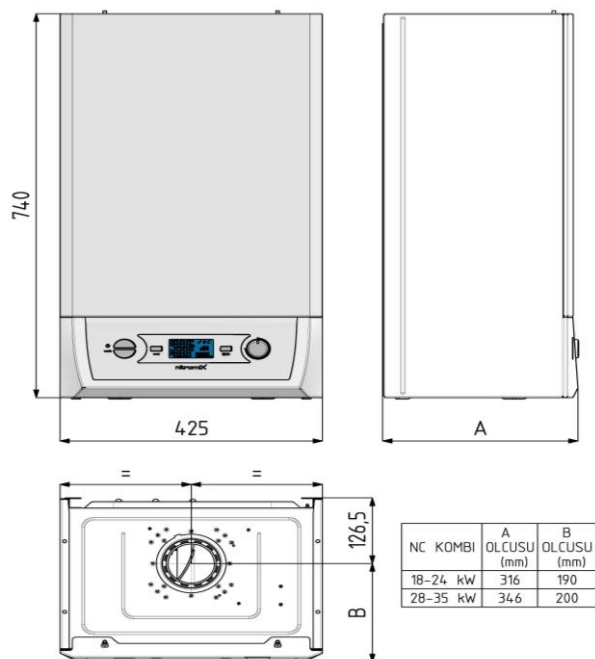

- 1 Σολήνα συμπυκνωμάτων
2 Εξόδος σιφονιού

Η καπνοδόχος πρέπει να έχει κλίση 44 χιλ./μέτρο

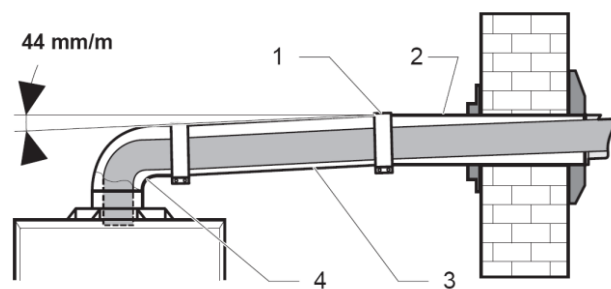

5. Τύποι εγκατάστασης

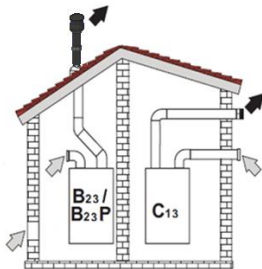
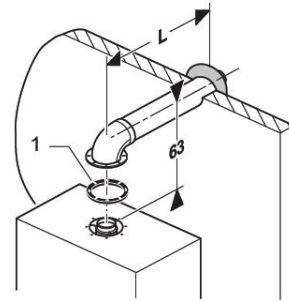
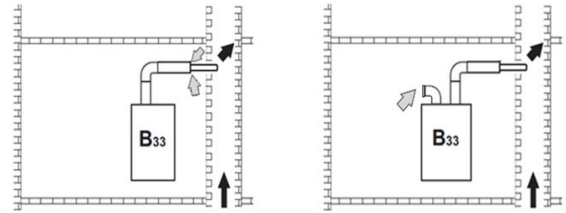
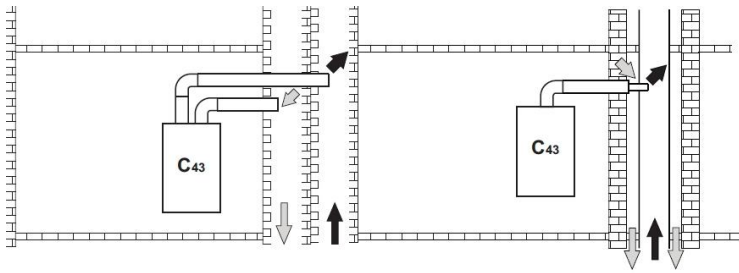
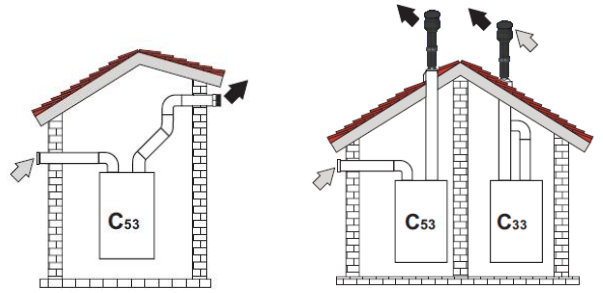
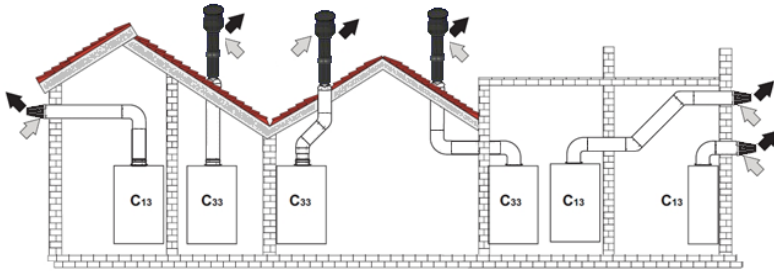

Διάμετρος καπνοδόχου	Μέγιστο μήκος
Ø60/100	6 m

Κάθε γωνία 90° ή δύο 45° αφαιρεί 1 μέτρο καπνοδόχου.

Διάμετρος καπνοδόχου	Μέγιστο μήκος
Ø80	30 m

Κάθε γωνία 90° ή δύο 45° αφαιρεί 1 μέτρο καπνοδόχου.

6. Προσπέλαση στο εσωτερικό του μηχανήματος

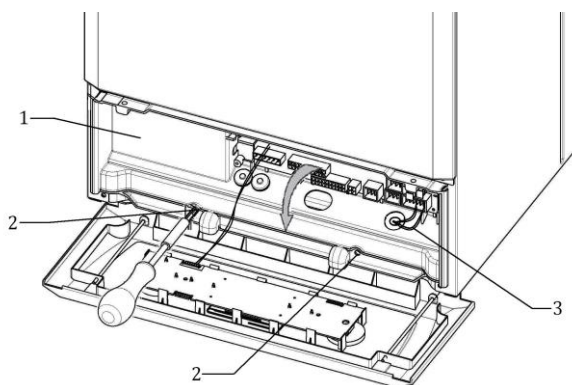
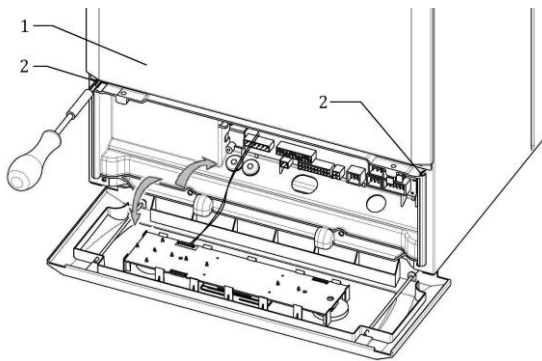
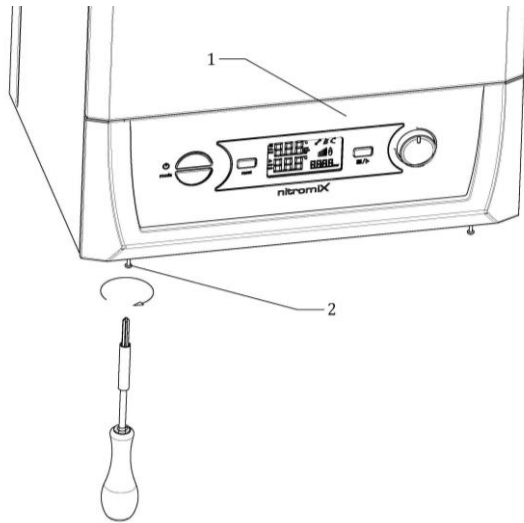

- 1 Πίνακας ελέγχου
- 2 Βίδες ασφαλείας
- 3 Σύνδεση καλωδίου παροχής ρεύματος

7. Σύνδεση παροχής ρεύματος

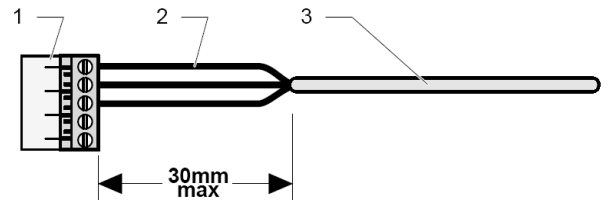

- Key
- 1 Σύνδεση
 - 2 Καλώδια
 - 3 Μόνωση καλωδίου

8. Καλώδιο ηλεκτρικής παροχής

Η παροχή του ρεύματος πρέπει να είναι 220 V και 50 HZ. Ασφαλίζεται με ασφάλεια 3 A στην πλακέτα

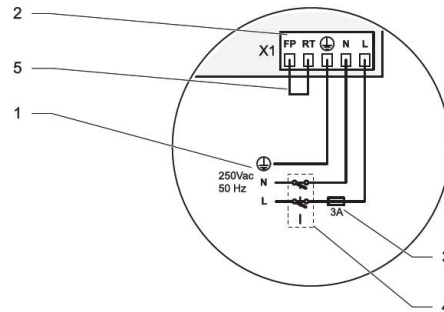

- 1 230V παροχή ρεύματος
- 2 Κεντρική ηλεκτρική σύνδεση
- 3 Ασφάλεια
- 4 Διπλός διακόπτης
- 5 Γέφυρα

9. Πρόσθετες συνδέσεις

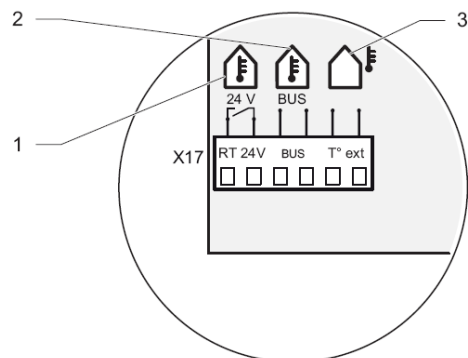

- 1 Θερμοστάτης 24V
- 2 Θερμοστάτης Ebus ή σύνδεση Ebus τηλεειδοποίηση
- 3 Εξωτερικός αισθητήρας θερμοκρασίας

10. Ηλεκτρικό διάγραμμα

DESCRIPTION

- B : BLACK
- BR : BROWN
- R : RED
- Y/G : YELLOW/GREEN
- BL : BLUE
- G : GREEN
- GY : GREY
- W : WHITE
- P : PINK
- O : ORANGE
- PP : PURPLE
- Y : YELLOW

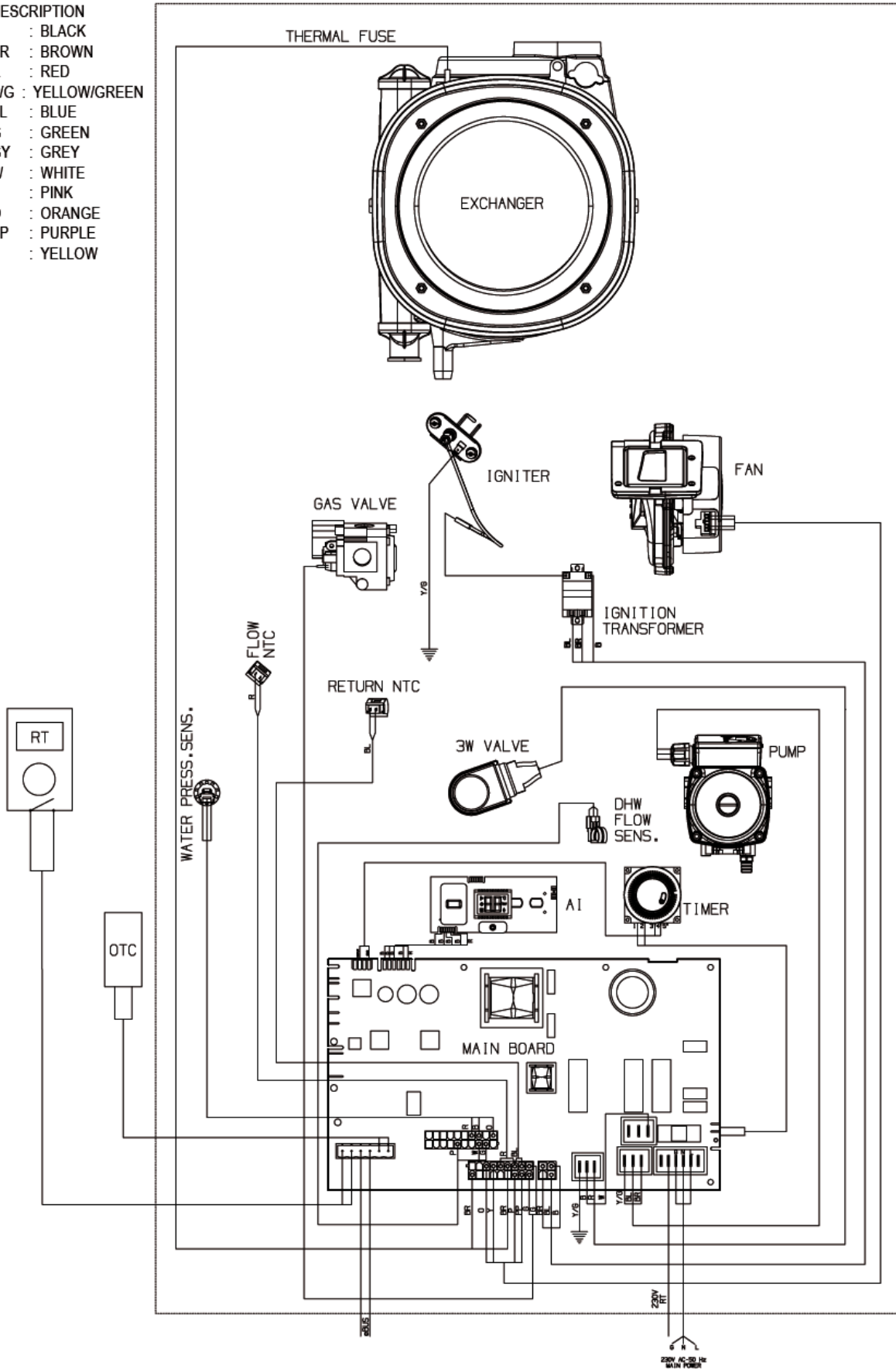



11. Διαδικασία έναυσης του λέβητα

Η έναυση πρέπει να γίνεται από αδειούχο τεχνίτη.

- Μην λειτουργείτε την συσκευή χωρίς νερό.
- Ανοίξτε τον διακόπτη του ρεύματος.

Πλήρωση με νερό την εγκατάσταση

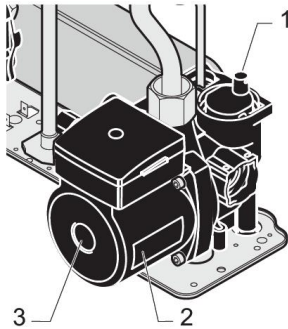

- 1 Αυτόματο εξαεριστικό
- 2 Κυκλοφορητής
- 3 Βίδα ξεμπλοκαρίσματος του κυκλοφορητή.

Εάν η πίεση του νερού πέσει κάτω από 0,4 bar, η οθόνη θα αναβοσβήσει την τρέχουσα πίεση και ο λέβητας δεν θα λειτουργήσει. Πρέπει να αυξήσετε την πίεση του νερού.

Πλήρωση με νερό του σιφωνιού της συμπύκνωσης

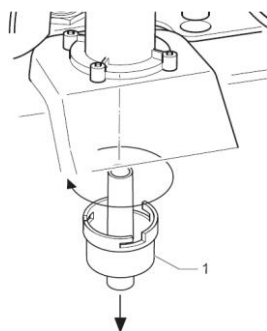

- Ξεβιδώστε το κάτω μέρος του σιφωνιού και γεμίστε το με νερό κατά 3/3.

12. Πίνακας ελέγχου



1. Διακόπτης ON/OFF
2. Επιλογή τρόπου λειτουργίας
 - a. Καλοκαίρι
 - b. Χειμώνα
3. Πλήκτρο RESET
4. Οθόνη (LCD)
5. Πλήκτρο επιλογής θερμοκρασίας για την θέρμανση και το ζεστό νερό χρήσης.
6. Ροοστάτης ρύθμισης θερμοκρασίας

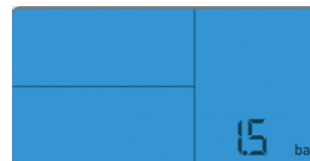
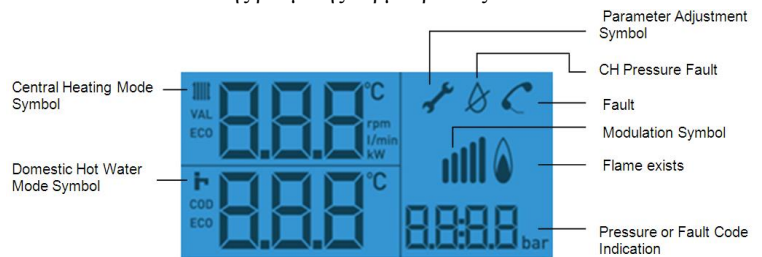

13. Λειτουργία τον Χειμώνα

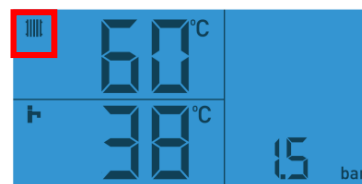

Για να ρυθμίσετε τη θερμοκρασία CH στην λειτουργία χειμώνα, πατήστε το κουμπί μια φορά και περιστρέψτε τον επιλογέα ρύθμισης της θερμοκρασίας δεξιόστροφα ή αριστερόστροφα. Στη λειτουργία χειμώνα, η οθόνη LCD δείχνει σύμβολα τόσο ζεστού νερού ταυτόχρονα. Αν DHW σύμβολο αναβοσβήνει, υπάρχει η χρήση του ζεστού νερού. Αν CH σύμβολο αναβοσβήνει υπάρχει η λειτουργία του λέβητα για το CH. Η θερμοκρασία του νερού μπορεί να ρυθμιστεί από το ελάχιστο των 10 ° C έως 75 ° C σε χρήση θερμαντικών σωμάτων, και η θερμοκρασία του νερού μπορεί να ρυθμιστεί από το ελάχιστο των 10 ° C έως 50 ° C σε ενδοδαπέδια θέρμανση. Η θερμοκρασία του νερού μπορεί να ρυθμιστεί από το ελάχιστο των 38 ° C κατ'ανώτατο όριο των 60 ° C.

14. Λειτουργία το Καλοκαίρι

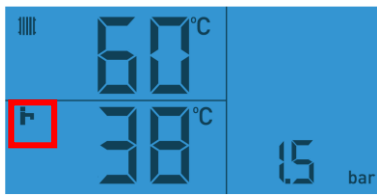

Για τη λειτουργία του λέβητα για παραγωγή ζεστού νερού το καλοκαίρι, πατήστε το πλήκτρο "MODE" μία φορά για να ορίσετε την επιλογή τρόπου λειτουργίας. Η θερμοκρασία μπορεί να ρυθμιστεί με τη στροφή "κουμπί ελέγχου θερμοκρασίας" στον πίνακα ελέγχου. Η θερμοκρασία του νερού μπορεί να ρυθμιστεί από το ελάχιστο των 38 ° C κατ' ανώτατο όριο των 60 ° C.

15. Παροχή αερίου

Η παροχή από το δίκτυο του αερίου πρέπει να είναι τουλάχιστον 20 mbar.

Μέτρηση της πίεσης από δίκτυο

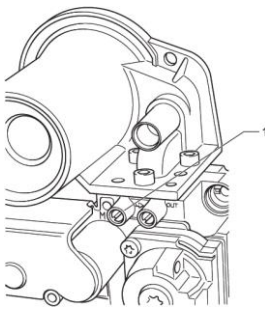

1 Σημείο μέτρησης

- Πίεση λειτουργίας με φυσικό αέριο (G20) 20mbar.
- Πίεση λειτουργίας με υγραέριο LPG (G31) 37mbar.

Παροχές αερίου

Model	Gas Rates (G20)				Gas Rates (G31)	
	(Approx.) After 10 mins from cold.					
	MIN		MAX		MIN	MAX
	m ³ /h	ft ³ /h	m ³ /h	ft ³ /h	kg/h	kg/h
P24	0,662	23,379	2,527	89,241	0,39	1,50
P28	0,882	31,148	2,97	104,89	0,52	1,76
P35	0,738	26,062	3,852	136,03	0,43	2,22

1m³ Propane – 1.87 kg

16. Ρύθμιση παραμέτρων

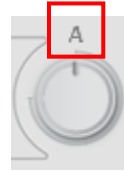

- Για να ρυθμίσετε τις παραμέτρους:

- Γυρίστε το κουμπί ρύθμισης θερμοκρασίας στην θέση "A" και πατήστε το πλήκτρο "mode" για περισσότερο από 7 δευτερόλεπτα για να αποκτήσετε πρόσβαση στο μενού ρυθμίσεων. Η οθόνη εμφανίζει την ένδειξη "0". Βάζετε τον κωδικό για service (35) ή ο εγκαταστάτης (96) γυρίζοντας το κουμπί ρύθμισης της θερμοκρασίας

- Πατήστε το κουμπί "mode" για να εμφανιστεί το "d.00" στην οθόνη LCD. Το νούμερο της παραμέτρου μπορεί να επιλεγεί από την περιστροφή του "διακόπτη ρύθμισης της θερμοκρασίας" και η τιμή της παραμέτρου μπορεί να εμφανισθεί στο πάνω αριστερό μέρος της οθόνης.

- Για να ρυθμίσετε την τιμή της παραμέτρου, πατήστε το πλήκτρο "ON / OFF" μία φορά. Όταν η τιμή της παραμέτρου αρχίζει να αναβοσβήνει για 3 φορές, η παράμετρος μπορεί να ρυθμιστεί γυρίζοντας το "κουμπί ρύθμισης της θερμοκρασίας" και η επιλεγμένη τιμή μπορεί να σωθεί, πατώντας το κουμπί "mode".

- Πατήστε το κουμπί ON / OFF μια φορά, για να κλείσετε το μενού παραμέτρων.

Σημείωση: η μείωση της ισχύος θέρμανσης δεν έχει καμία επίδραση στην παραγωγή ζεστού νερού χρήσης.

Ρύθμιση παραμέτρων

Κωδικός	Παράμετρος	Περιγραφή	Κωδικός ρύθμισης	Εργοστασιακή ή ρύθμιση	Ελάχιστη τιμή	Μέγιστη τιμή	Μονάδα ρύθμισης	Μεταβλητή Μ / Σταθερά Σ
d00	Μέγιστη ισχύς (kW)	Επιλογή για το 24>8 to 18 και 28>9 to 24	35-96	P 24: 23 P 28: 27 P 35: 35	P 24: 6 P 28: 8 P 35: 6,7	P 24: 23 P 28: 27 P 35: 35	kW	M
d01	Λειτουργία κυκλ/τή θέρμανση	Χρονική λειτουργία κυκλ/τή	35-96	5	2	60	λεπτά	M
d02	Χρόνος επανεργοποίησης καυστήρα στην θέρμανση	Υπολογισμός του χρόνου.	35-96	20	2	60	λεπτά	M
d08	Θερμοστάτης 230V 0=απενεργοποίηση 1=ενεργοποίηση	Θερμοστάτης 230V	35	N/A	0	1	on/off	Σ
d10	Κυκλοφορητής: 1=σε λειτουργία 0=ανενεργός	Κατάσταση του κυκλοφορητή	35	N/A	0	1	on/off	Σ
d16	Θερμοστάτης 24V 0= απενεργοποίηση 1= ενεργοποίηση	Θερμοστάτης 24V	35	N/A	0	1	on/off	Σ
d17	Ρύθμιση θερμοκρασίας: προσαγωγή/επιστροφή	Ρύθμιση θερμοκρασίας σε σχέση με τους προσαγωγής/επιστροφής αισθητήρες.	35	0	0	1	Σωστό/λάθος	M
d18	Τρόπος λειτουργίας κυκλοφορητή	0=με τον καυστήρα 1=με τον θερμοστάτη 2=με τον χειμώνα	35- 96	1 με θερ/τη	0	2	ενδειξη	M
d20	Μέγιστη θερμοκρασία Z.N.X.		35- 96	60	50	60	°C	M
d22	Ζήτηση Z.N.X.: 1=on, 0=off		35	N/A	0	1	on/off	Σ
d23	Τρόπος λειτουργίας (1=χειμώνας, 0=καλοκαίρι)		35	N/A	0	1	ενδειξη	Σ
d25	Λειτουργία λέβητα 1=on 0=off		35	N/A	0	1	on/off	Σ
d34	Ταχύτητα ανεμιστήρα	ταχύτητα	35-96	N/A	N/A	N/A	rpm/100	Σ
d36	Παροχή αισθητήρα Z.N.X.	τιμή	35-96	N/A	N/A	N/A	l/dk	Σ
d40	Θερμοκρασία αισθητήρα προσαγωγής θέρμανσης	τιμή °C	35-96	N/A	N/A	N/A	°C	Σ
d41	Θερμοκρασία αισθητήρα επιστροφής θέρμανσης	τιμή °C	35-96	N/A	N/A	N/A	°C	Σ
d50	Ελάχιστη ταχύτητα ανεμιστήρα rpm/10	ταχύτητα	35	P 24: 30 P 28: 42 P 35: 25	0	99	rpm/10	M
d51	Μέγιστη ταχύτητα ανεμιστήρα rpm/10	ταχύτητα	35	P 24:-45 P 28:-70 P 35:-45	-99	0	rpm/10	M
d64	Μέσος χρόνος ανάφλεξης		35	0	0	0	δευτερ.	Σ

d65	Μέγιστος χρόνος ανάφλεξης		35	0	0	0	δευτερ.	Σ
d67	Χρόνος αναμονής για τον χρόνο επανεργοποίησης της θέρμανσης	Ενδειξη	35	0	0	255	λεπτά	Σ
d68	Αποτυχημένες αναφλέξεις στην πρώτη προσπάθεια	Ενδειξη	35	0	0	255	none	Σ
d69	Αποτυχημένες αναφλέξεις στην δεύτερη προσπάθεια	Ενδειξη	35	0	0	255	none	Σ
d71	Μέγιστη θερμοκρασία νερού στην θέρμανση	Επιλογή από 45-80°C	35-96	75	45	80	°C	M
d80	Ωρες λειτουργίας στο Z.N.X.	Ενδειξη	35	0	0	65535	h	Σ
d81	Ωρες λειτουργίας στην θέρμανση	Ενδειξη	35	0	0	65535	h	Σ
d82	Αριθμός εκκινήσεων του καυστήρα στην θέρμανση (ένδειξη X 100)	Ενδειξη	35	0	0	65535	none	Σ
d83	Αριθμός εκκινήσεων του καυστήρα στο Z.N.X. (ένδειξη X 100)	Ενδειξη	35	0	0	65535	none	Σ
d85	Ελάχιστη ισχύς στην θέρμανση	Ενδειξη	35-96	P 24: 6 P 28: 8 P 35: 7	P 24: 6 P 28: 8 P 35: 7	P 24: 23 P 28: 27 P 35: 7	kW	M
d93	Επιλογή τύπου λέβητα	Ενδειξη	35	P 24: 0 P 28: 1 P 35: 4	0	32	none	M
d94	Καθάρισμα μνήμης σφαλμάτων		35-96		0	1	σωστό/λάθος	M
d95	Εκδοση προγράμματος	Ενδειξη έκδοσης 1. Πίνακας ελέγχου 2. Από δίκτυο	35	0			none	Σ
d96	Επαναφορά εργοστασιακών ρυθμίσεων	0= ανενεργό 1= ενεργό	35		0	1	σωστό/λάθος	M

15. Μνήμη σφαλμάτων

- Αυτό το μενού σας επιτρέπει να εμφανίσετε τις 10 πιο πρόσφατες βλάβες της συσκευής.
- Γυρίστε τον "διακόπτη ρύθμισης θερμοκρασίας" σε ένα σημείο εκτός από το σημείο "A". Πατήστε το κουμπί "MODE" για 3 δευτερόλεπτα. μέχρι η ένδειξη "01" εμφανισθεί στην οθόνη.
- Η οθόνη θα εμφανίσει το πρώτο λάθος "F.XX".
- Για να εμφανίσετε τις τελευταίες 10 βλάβες που έχουν καταγραφεί από τη συσκευή, στρέψτε το "κουμπί ρύθμισης θερμοκρασίας"
- Για να εγκαταλείψετε το μενού, πατήστε το πλήκτρο "ON / OFF" μία φορά.

Εγγραφή	Κωδικός σφάλματος	Περιγραφή
01	F.XX	Consult the "Fault codes" chapter.
02	F.XX	Consult the "Fault codes" chapter.
03	F.XX	Consult the "Fault codes" chapter.
04	F.XX	Consult the "Fault codes" chapter.
05	F.XX	Consult the "Fault codes" chapter.
06	F.XX	Consult the "Fault codes" chapter.
07	F.XX	Consult the "Fault codes" chapter.
08	F.XX	Consult the "Fault codes" chapter.
09	F.XX	Consult the "Fault codes" chapter.
10	F.XX	Consult the "Fault codes" chapter.

15.1. Κωδικοί σφαλμάτων

Περιγραφή	Κωδικός	Αιτία	Λύση
Αισθητήρας προσαγωγής	F00	Αποσυνδέθηκε καλώδια ή ελαττωματικό αισθητήρα	-Ελεγχος των συνδέσεων και της καλωδίωσης -Ελεγχος των συνδέσεων
Αισθητήρας επιστροφής	F01	Αποσυνδέθηκε καλώδια ή ελαττωματικό αισθητήρα	
Αισθητήρας προσαγωγής	F10	Βραχυκυκλωμένα καλώδια ή ελαττωματικό αισθητήρα	
Αισθητήρας επιστροφής	F11	Βραχυκυκλωμένα καλώδια ή ελαττωματικό αισθητήρα	
Υπερθέρμανση	F20	Θερμοκρασία λέβητα πάνω από το όριο.	-Ελεγχος λειτουργίας κυκλοφορητή - Ελεγχος καλωδιώσεων
Πίεση νερού	F22	- Μικρή πίεση νερού στον λέβητα.	-Συμπλήρωση με νερό -Ελεγχος για διαρροές
Μεγάλη διαφορά θερμοκρασίας προσαγωγής/επιστροφής	F23	Μη καλή κυκλοφορία νερού	-Ελεγχος κυκλοφορητή -Ελεγχος συνδέσεων των αισθητήρων
Βλάβη στις βαλβίδες αερίου	F26	Αποσυνδεδεμένα ή κατεστραμμένα καλώδια	-Ελεγχος των συνδέσεων -Ελεγχος της λειτουργίας των βαλβίδων
Βλάβη στην ανίχνευση της φλόγας	F27	Σφάλμα ιονιστή	-Ελεγχος του ιονιστή -Ελεγχος των συνδέσεων στην πλακέτα -Ελεγχος της υψηλής τάσης
Πρόβλημα ανάφλεξης	F28	Ανεπαρκής ροή αερίου	-Ελεγχος των διακοπών αερίου -Ελεγχος της τιμής του CO ₂
Πρόβλημα ανάφλεξης	F29	Ελλειψη αερίου	-Ελεγχος των καλωδίων υψηλής τάσης -Ελεγχος του καλωδίου ανάφλεξης
Μη καλή παροχή αέρα	F32	Μη καλή ταχύτητα ανεμιστήρα	-Ελεγχος της καπνοδόχου -Ελεγχος των καλωδίων του ανεμιστήρα
Μη σωστή τάση EBUS	F49	Βραχυκύκλωμα στην σύνδεση EBUS	-Ελεγχος των καλωδίων eBUS
Βλάβη πλακέτας	F61	Σφάλμα εντολής βαλβίδων αερίου	-Ελεγχος των καλωδίων στην πλακέτα. -Ελεγχος πλακέτας -Ελεγχος σωστού κωδικού μηχανήματος στην πλακέτα -Επανεκκίνηση λέβητα
	F62	Κλειστές βαλβίδες αερίου	
	F63	Σφάλμα μνήμης πλακέτας	
	F64	Ταχεία αύξηση της θερμοκρασίας προσαγωγής ή επιστροφής	
	F65	Υπερβολική θερμοκρασία πλακέτας	
	F67	Σφάλμα σήματος στην πλακέτα	
Διακύμανση φλόγας	F68	Ανεπαρκής ροή του φυσικού αερίου Εσφαλμένη ρύθμιση της βαλβίδας αερίου Ελαττωματικό ηλεκτρόδιο ανάφλεξη και έλεγχος φλόγας / ελαττωματική μονάδα ανάφλεξη.	-Ελεγχος του CO ₂ -Ελεγχος των καλωδίων ανάφλεξης
Αισθητήρας προσαγωγής	F71	Αποσυνδεδεμένα καλώδια	-Ελεγχος καλωδίων -Ελεγχος σωστής θέσης του αισθητήρα
Μόνιμη διαφορά θερμοκρασίας προσαγωγής/επιστροφής	F72	Ασυμφωνία θερμοκρασίας θέρμανσης επιστροφή	-Ελεγχος καλωδίων αισθητήρα -Αντικατάσταση αισθητήρα
Αισθητήρας πίεσης	F73	Αποσυνδεδεμένες ή βραχυκυκλωμένες καλωδιώσεις	-Ελεγχος καλωδιώσεων -Ελεγχος αισθητήρα
Αισθητήρας πίεσης	F74	Πρόβλημα στον αισθητήρα πίεσης	
Θερμική ασφάλεια	F76	Καλωδίωση-Μη σωστή επαφή	- Ελεγχος καλωδιώσεων -Αντικατάσταση του εναλλάκτη
Βαλβίδα αερίου	F77	Προβληματική βαλβίδα αερίου	- Ελεγχος καλωδιώσεων -Ελεγχος λειτουργίας βαλβίδων
Lack of water: Although burner is lit, temperature doesn't increase.	F83	- Return water valve closed. -Water leakage in the system. -Lack of water in the system.	-Fill the sytem. -Purge the system -Check the pump connections. -Check the flow and return heating sensor connections. -Check that there are no leakage.
Permanent temperature difference between flow	F84	-Inverted or disconnected flow and return heating temperature sensors (permenant	-Check the sensor connections -Replace faulty sensor

<i>and return</i>		<i>difference)</i> <i>-Defected temperature sensors</i>	
<i>Flow and heating sensors fault</i>	<i>F85</i>	<i>Flow and return heating temperature sensor connected to the same tube.</i>	<i>-Check the temperature sensor connections</i>
<i>Underfloor heating contactfault</i>	<i>F86</i>	<i>Open contact of floor heating Disconnected or defected Sensor</i>	<i>-Check the sensor connections</i> <i>-Check that the sensor is connected to the main board and the shunt is removed.</i>
<i>User interface fault</i>	<i>Err</i>	<i>Defected user interface</i>	<i>-Check connection from user interface PCB to main board.</i> <i>-Replace user interface</i>

13.1. Functional flow diagram

13.1.1. Central Heating

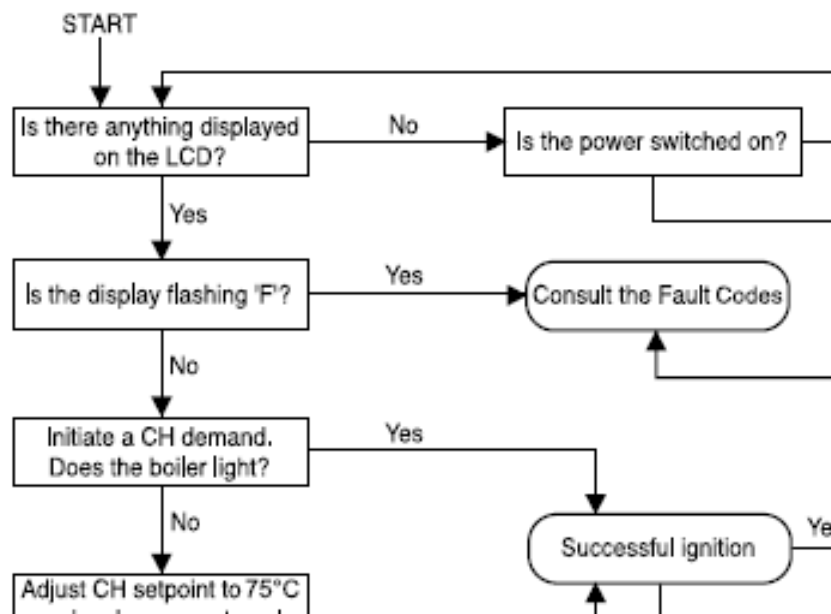

13.1.2. Domestic Hot Water

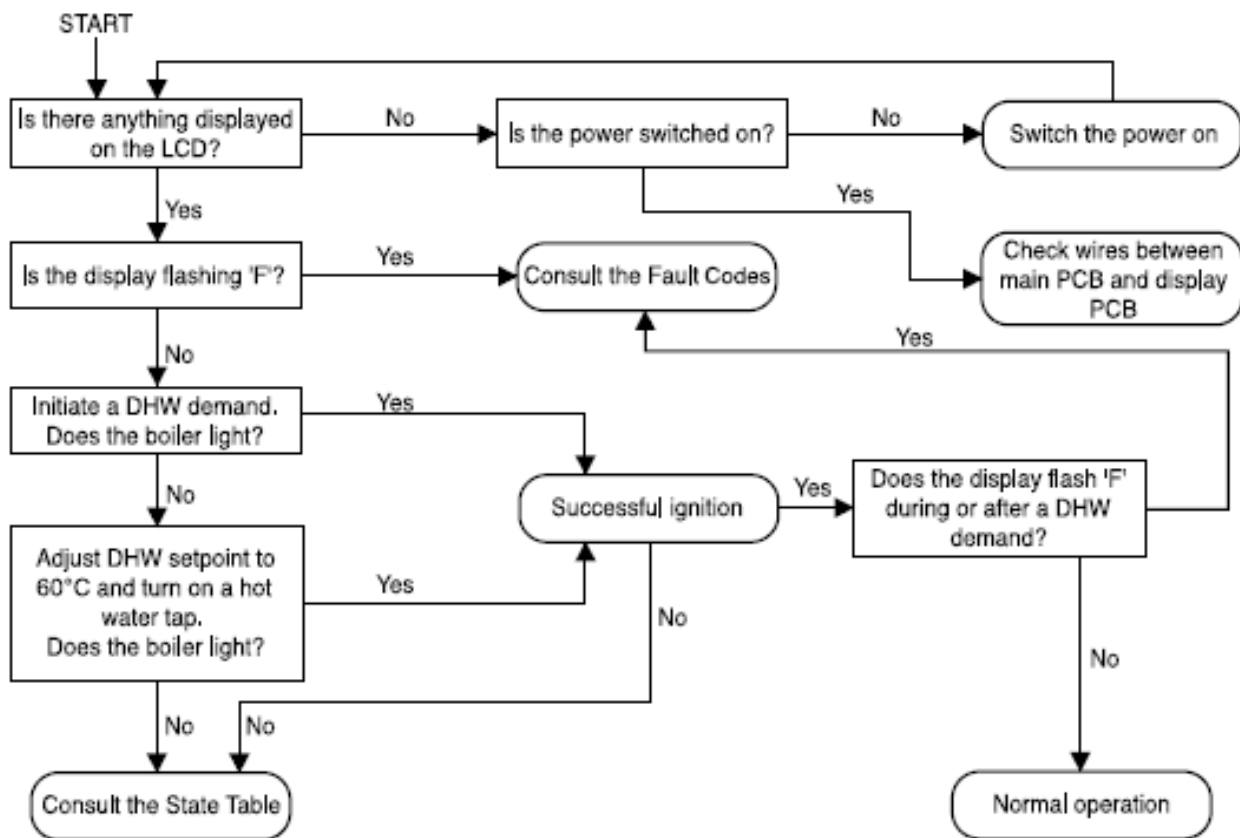

14. Gas conversion adjustments

In order to operate with a gas other than that provided from the factory, it is necessary to some adjustments to the gas valve.

This conversion should only be carried out by a competent person.

- During the conversion to Propane, use of a suitable flue gas analyser is necessary.

15. Draining

15.1. Heating circuit

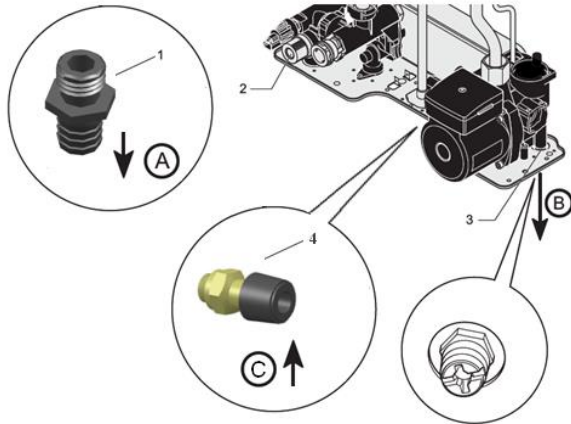

Key

- 1 Draining outlet
- 2 Pressure relief valve PRV
- 3 Appliance drain tap
- 4 Water pressurise
- A PRV outlet - to outside
- B Appliance drain
- C Filling valve

- Drain down the heating circuit of the boiler only, by closing the heating flow and return isolating valves. See chapter "Hydraulic connection ► Gas and water connections"

- Attach a length of hose (1) to the drain point and open the drain valve (2).

- After draining, close the drain valve (2) and remove the hose.

15.2. Domestic Hot water circuit

- Drain the Domestic Hot Water circuit by closing the coldwater isolation valve on the wall mounting jig.

- Open one or more hot water taps to drain the hot water circuit.

16. Servicing

- To ensure the continued efficient and safe operation of the boiler it is recommended that it is checked and serviced as necessary at regular intervals.

The frequency of servicing will depend upon the particular installation conditions and usage.

If this appliance is installed in a rented property there is a duty of care imposed on the owner of the property by the current issue of the Gas Safety (Installation and Use) Regulations.

- Servicing/maintenance should be carried out by a **competent person** approved at the time by the Health and Safety Executive in accordance with the rules in force in the countries of destination.

- To obtain service, please call your installer or Demirdoküm' s own service organisation.

PLEASE NOTE: During routine servicing, and after any maintenance, we recommend that the following must be checked:

- The integrity of the flue system and the flue seals,
- The integrity of the boiler combustion circuit and the relevant seals,
- The operational (working) gas inlet pressure at maximum rate,
- The gas rate,
- The combustion performance.

- See the "Safety instructions" chapter for a list of operations to be performed prior to the maintenance of the application.

- Once the maintenance operations have been completed, consult the "Start Up" chapter to restart the appliance.

16.1. Annual Maintenance

16.1.1. Verification of components

- Check that the flow sensor is working properly. See chapter "Specific adjustment ► Appliance technical settings and parameter list ► Installation settings" and use code "d.36".

- Check that the fan is working properly. See chapter "Specific adjustment ► Appliance technical settings and parameter list ► Installation settings" and use code "d.34".

- Check that the temperature sensors are working properly. See chapter "Specific adjustment ► Appliance technical settings and parameter list ► Installation settings" and use code "d.40, d.41".

- Check the ionisation quality.

- Check that the thermal fuse protects the appliance against dry fire. Disconnect the thermal fuse and check if "F76" fault code is displayed on the screen.
- Check that the pressure sensor is working properly. The pressure must be displayed on the screen.
- Check the pressure of the expansion vessel.

16.1.2. Other checks

- Check the CO₂ rate in the fuel and compare with the values indicated in the chapter "CO₂ Measurement".
- Check that there are no leaks in the joints and the safety valves
- Check that there are no gas leakage.
- Verify that the flue system is sound and complete.
- Check the appliance's electrical safety.

16.1.3. Cleaning of the components

- Clean the following components:
 - The heating filter
 - The condensate trap
 - The heat exchanger.
 - The burner
 - The fan

16.1.4. Corrosion and anti-sludge protection

In order to avoid corrosion, the addition of a corrosion inhibitor to the heating circuit water is recommended. The inhibitor will stop electrolytic reaction and bacterial growth between the different metals used in the installation.

It will also avoid the formation of gas which could be produced following the chemical reactions.

It is especially important to treat the water in underfloor heating systems, as low temperatures favour bacterial growth. This can lead to the formation of sludge, which in turn may block some or all of the circuits.

In order to add the correct dosage of these products, you must know the volume of water contained in the installation. It is recommended that you note down the volume for future needs.

The inhibitors must be compatible with the materials employed in the installation.

16.2. Combustion check and Setting the air gas ratio valve

16.2.1. Competency to carry out the check of combustion performance

The person carrying out a combustion measurement must be assessed as competent in the use of gas analyser and the interpretations of the results.

The flue gas analyser should be one meeting calibrated in accordance with the analyser manufacturers' requirements.

Ensure that the gas analyser is set to the correct fuel setting.

Adjust both CH and DHW temperatures to max. Then change the heating mode to DHW by pressing the "||||/■" button, refer to commissioning section. The boiler should fire automatically.



Safe combustion can only be verified by measuring CO/CO₂ ratio. This must not exceed the value shown in the table opposite.

16.2.2. Preliminaries

Prior to, during servicing and after any maintenance or changed parts, the following must be checked.

- The integrity of the flue system and flue seals.
- The integrity of the appliance combustion circuit and relevant seals.
- Electrical, gas and water connections.
- System pressure.
- The combustion performance, refer to the following procedure.
- The operational gas inlet pressure and gas rates refer to the commissioning chapter. Correct any fault before continuing.

Combustion check and Setting the air gas ratio

- Remove the front casing panel and pull the control box into the service position as described previously. Taking care not to touch any internal components, proceed as follows.

- Connect the CO₂ combustion analyser to the relevant test point. (see below figure)

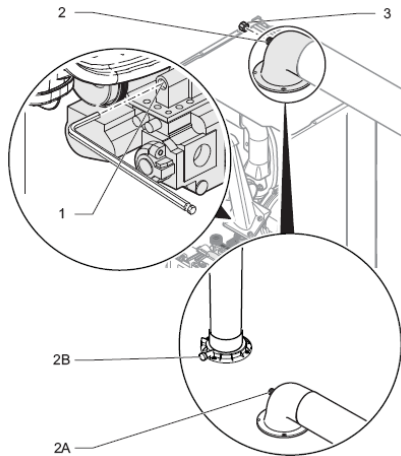

- Key**
- 1 Throttle
 - 2 Combustion analyser sample point
 - 2A Flue elbow
 - 2B Vertical flue adaptor
 - 3 Cap

16.2.3. Maximum rate check and adjustment

- Activate the test mode "P.01" and set the value to 99 in order to force the burner at P. max. See chapter "Specific adjustment ► Appliance technical settings and parameter list ► Test modes".
- Wait approximately 5 minutes to read a stabilized CO₂ value.
- Check that the value is within the range specified table in the "check" column.

Gas Adjustment	P24		P28		P35		Ratio
	G20	G31	G20	G31	G20	G31	
CO ₂ case ON	9.3 ±0.3	10.5 ±0.3	9.2 ±0.3	10.2 ±0.3	9.6 ±0.3	10.2 ±0.3	<0.004
CO ₂ case OFF	9.1 ±0.2	10.3 ±0.2	9.0 ±0.2	10.0 ±0.2	9.4 ±0.2	10.0 ±0.2	<0.004

If the combustion reading is not within the acceptable values and the integrity of the complete flue system and combustion circuit seals have been verified and the inlet gas pressure (and gas rate) have been verified, then, it will necessary to adjust the combustion rate of the appliance.



Adjustment is made by turning the throttle an 1/8 of a turn, waiting 1 minute to allow the appliance to stabilise before checking or making further adjustments.

- Remove the sticker covering the "throttle" adjustment screw, if fitted.
- Rotate the "throttle" (1) (anti-clockwise to increase), to the required CO₂, refer to previous diagram and the "Setting" column in the table.,

- When you have finished, press the On/Off button to exit the test modes.
- Remove the analyser probe and replace the cap on the sampling point, replace the controls fascia, and the front casing panel.

Remember to replace the sample point cap on completion of the test.



16.2.4. Gas Rate Check

- Check the gas rates as described in the commissioning section.

16.2.5. Completion

If it is not possible to achieve the required results for either the combustion or gas rates, it will be necessary to complete a full service of the appliance and then repeat the combustion check procedure.

If after servicing and adjustment of the appliance the combustion values are still unacceptable and after further remedial work has been carried out, the appliance must be disconnected until the CO/CO₂ ratio is acceptable.

16.3. Servicing



If the Combustion CO₂, CO/CO₂ ratio & Gas rate checks did not require adjustment then it will not be necessary to complete a full service.

All routine servicing requirements can be achieved by the removal of the front panel.

- Position the control box into the service position.
- Before commencing with a service or replacement of parts, isolate the boiler from the electrical and gas supplies.

16.4. Silencer

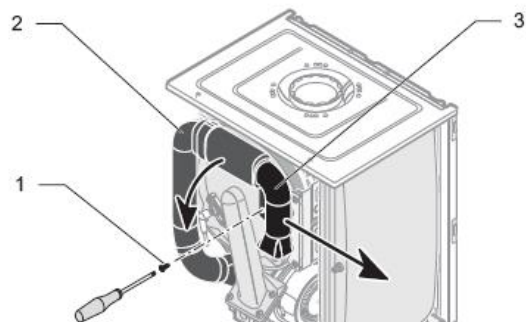

Key

- 1 Silencer retaining screw
- 2 Fixed silencer
- 3 Removable silencer

- Remove the silencer retaining screws (1) and remove the silencer (3).
- Clean the interior of the silencer with a dry cloth if necessary, taking care not to damage the internal foam.
- Repeat the operation in reverse order to replace the silencer.

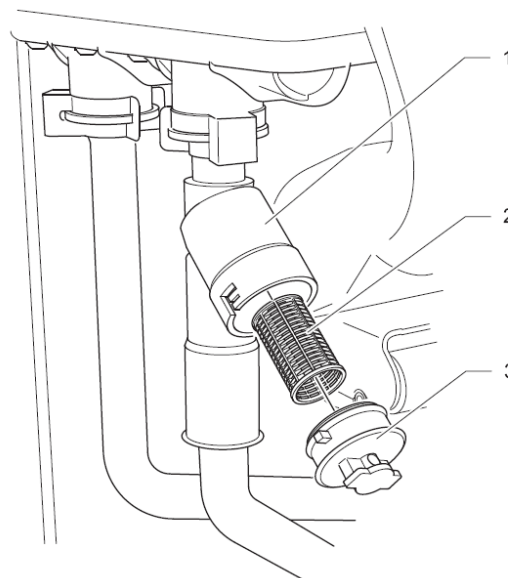

16.5. Expansion vessel

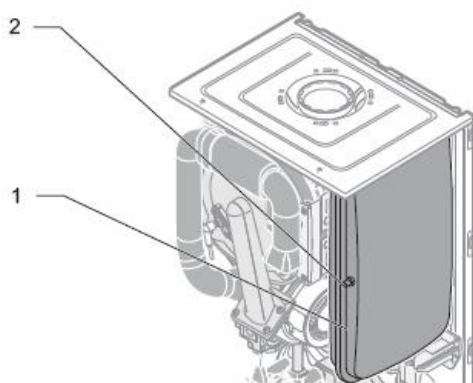

Key

- 1 Expansion vessel
- 2 Expansion vessel pressure inlet

- Check the expansion vessel's supply pressure (see « Technical Data » chapter) by means of the pressure inlet located on the expansion vessel. Adjust the pressure if necessary.
- Following the installation of a new expansion vessel, fill and purge the appliance or installation, if necessary.

Key

- 1 Filter housing
- 2 Filter
- 3 Filter cap

There is a filter fit that projects the plate heat exchanger from blockage.

- After draining the boiler as previously described push and turn the filter cap in an anti-clockwise direction to release it from its housing.
- Pull the cap out with the filter attached.
- Clean and replace as necessary refilling and re-pressurising the boiler as required.

16.6. Plate heat exchanger filter

16.7. Heating filter

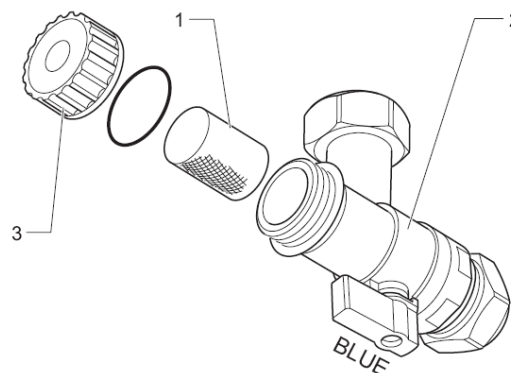

Key

- 1 Filter
- 2 Filter valve body
- 3 Cap

The filter valve located under the boiler at the right hand side prevents debris from entering the boiler. Should this become blocked.

- Shut off the heating flow and return filter valve by turning the levers clockwise.
- Drain the boiler from the drain cock behind the pump or by removing the cap “3” from the filter valve.
- Remove and clean the filter and refit in reverse order, topping up the water pressure via the filling loop as required.

- Reassemble the components, taking care to position the gaskets correctly.
- Fill the reservoir (2) before assembly.

16.8. Condensate Trap

 **Warning: condensate is mildly acidic. Use protective gloves.**

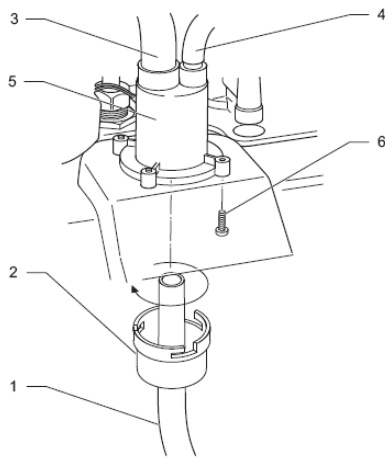

Key

- 1** Condensate outlet
- 2** Condensate reservoir
- 3** Condensate drain
- 4** Rain water collector
- 5** Condensate trap
- 6** Condensate retaining screw

- Place a container under the condensate trap (5)
- Disconnect the condensate pipe from the reservoir (1)
- Disconnect the condensation reservoir (2)
- Disconnect the condensate drain (3) and the rain water collector (4) from the heat exchanger.

The condensate trap will contain water, lift taking care not to spill the water.

- Remove the screws (6) to disconnect the condensate trap (5)
- Clean the hose, the trap and siphon, remove any accumulated dirt.

16.9. Combustion block

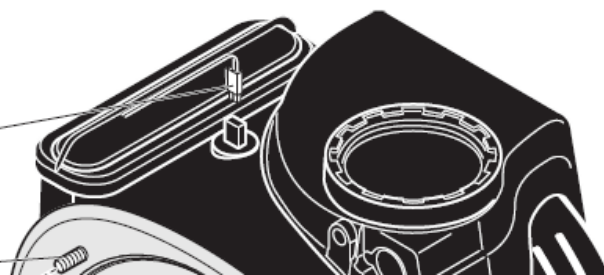

Legend

**1 Gas valve connection
2 Grounding cable
3 Spark electrode inlet
4 Spark electrode retaining screw.
5 Spark electrode gasket
6 Spark electrode
7 Burner retaining nut
8 Burner retaining screw
9 Thermal fuse connection
10 Coil**

**11 Heat exchanger
12 Burner door seal
13 Burner
14 Gas valve
15 Fan
16 Fan connection
17 Gas pipe**

16.9.1. Spark electrode

- Disconnect the electrode inlet (3) and the grounding cable (2).
- Remove the 2 spark electrode retaining screws (4).
- Carefully remove the electrode from the combustion chamber.
- Check that the extremes of the electrode (6) are not damaged.

- Clean away any accumulation of dirt and check that the distance between the two electrodes is between 3.5 and 4.5 mm.
- Check that the gasket (5) is not damaged. Replace if necessary.

16.9.2. Removing the combustion / door assembly



DO NOT REMOVE the burner door, unless you have checked the flame picture and the combustion with a flue gas analyser and found a problem. Otherwise it will not be necessary to remove the burner door.
Warning: The burner door seal (12) and nuts (7) must be replaced each time the burner door is removed and at least every 5 years. Note: the nuts are supplied with the seal.

- Disconnect the spark electrode connector (6) from the igniter unit.
- Remove the gas pipe (17).
- Remove the connectors from the gas valve (1) and the fan (15).
- Remove the retaining screw of the silencer.
- Loosen the 4 nuts (7).
- Remove the burner group from the heat exchanger (11).
- The studs (8) fixed to the heat exchanger must not be damaged. Should it be damaged, replace the heat exchanger.
- The burner gate insulation should not be damaged. Replace if damaged.

16.9.3. Cleaning the heat exchanger

- Clean the coil (19) in the heat exchanger (11) with water.

16.9.4. Burner control

- The burner (13) does not require maintenance and should not be cleaned.
- Check that its surface is not damaged. Replace the burner if necessary.
- Following the verification or replacement of the burner, assemble the burner group as described in the following chapter.

16.9.5. Re-assembling the burner group

- Place the burner group on the heat exchanger (11).
- Progressively tighten the 4 nuts (7) in an alternate order.
- Reassemble the silencer.
- Connect the gas tube (17) with a new gasket to the burner group.
- Connect the spark electrode connector (6) to the igniter unit.
- Connect the connector to the gas valve (1) and the fan (15).
- Open the appliance gas input.
- Check the watertightness of the gas connection.

16.9.6. Service completion

- Re-check the combustion, see chapter "Combustion check".

17. Replacement of Parts

- Do not use reconditioned or copy parts, only use original parts supplied by Demirdoküm
- If a part is required, contact the Demirdoküm service organisation.
- Please quote the name of the appliance, this information will be on the name badge on the front of the appliance.

- If in doubt seek advice from the local gas company or Demirdoküm's own service organisation.



Replacement of parts must be carried out by a competent person approved at the time by the Health and Safety Executive.

PLEASE NOTE: During change of part of the combustion circuit, we recommend that the following must be checked:

- The integrity of the flue system and the flue seals,
- The integrity of the boiler combustion circuit and the relevant seals,
- The operational (working) gas inlet pressure at maximum rate,
- The gas rate,
- The combustion performance.

17.1. General



The replacement of parts described in sections "Combustion block" will require the removal of the burner module assembly and the replacement of seal and self locking nuts.

Replacement parts that have associated components that need replacing on removal, i.e. 'O' ring, seals, gasket, etc., will be supplied and should be fitted.

- Before replacing any parts of the boiler, isolate from the mains electric supply and turn off the gas at the gas service isolation valve on the boiler.
Unless stated otherwise parts are replaced in the reverse order to removal.
- After replacing any parts, always test for gas soundness and if necessary carry out functional test of the controls.

17.2. Boiler Access

For replacement of parts, the front casing panel of the boiler will need to be removed.

- To remove undo the two screws on the underside of the front casing and lift off.

17.3. Viewing window

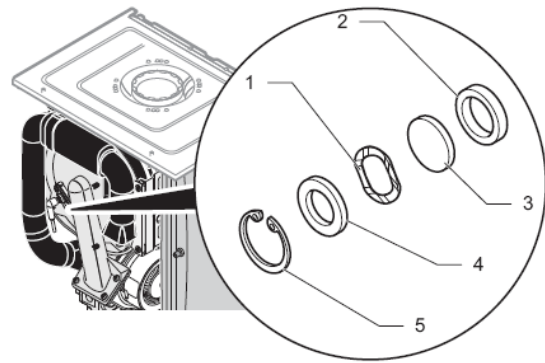

- Key**
- 1 Fibre washer
 - 2 Steel washer
 - 3 Glass
 - 4 Steel washer
 - 5 Circlip

- Remove the circlip (5).
- Remove the steel washer (4).
- Remove fibre washer (1).
- Remove the glass (3).

17.4. Expansion vessel

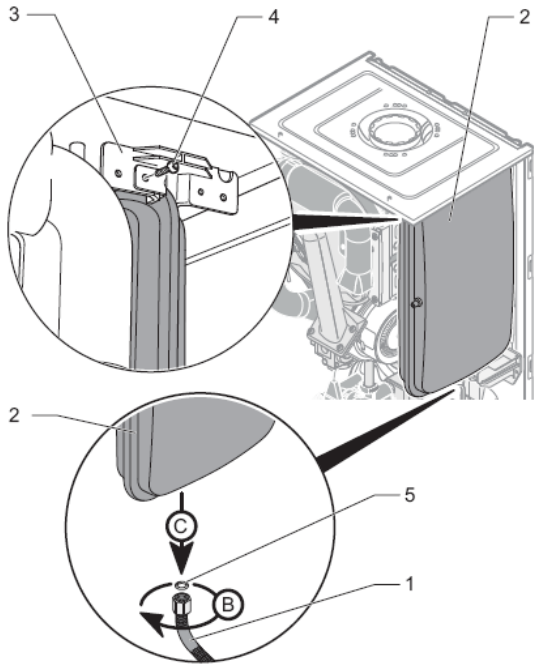

Key

1 Connector (flexible hose)

2 Expansion vessel

3 Upper support bracket

4 Retaining screw

5 Gasket

Drain the boiler heating circuit as described in the appropriate chapter "Draining".

- Remove two screws (4).
- Undo the connector (1) at the base of the vessel.
- Remove the expansion vessel (2).
- Fit a new gasket between the expansion vessel and connector.
- Refill, vent and pressurise the boiler.

17.5. Hydraulic block

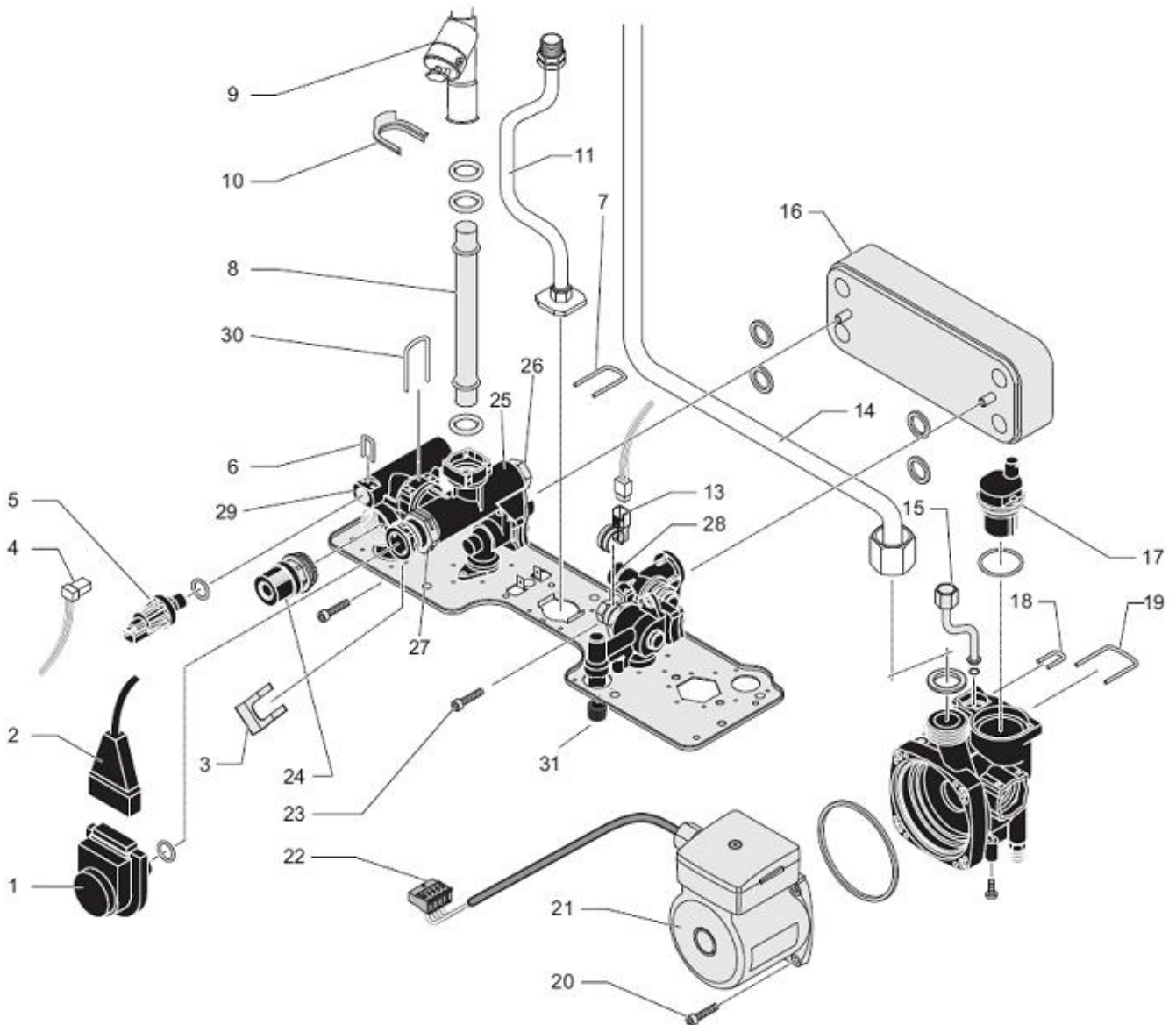

Key

- | | | | |
|----|--|----|--|
| 1 | Three-way valve motor | 17 | Automatic air vent |
| 2 | Three-way valve electrical plug | 18 | Expansion vessel pipe clip |
| 3 | Three-way valve electrical plug retaining clip | 19 | Automatic air vent retaining clip |
| 4 | Low water pressure sensor connector | 20 | Pump head retaining screws |
| 5 | Low water pressure sensor | 21 | Pump housing |
| 6 | Low water pressure sensor retaining clip | 22 | Pump head connector |
| 7 | Heating flow pipe retaining clip | 23 | Plate-to-plate heat exchanger retaining screws |
| 8 | Heating flow pipe | 24 | Safety Discharge Valve |
| 9 | Heating flow pipe filter assembly | 25 | Bypass Valve |
| 10 | Heating flow pipe retaining clip | 26 | Bypass Valve retaining nut - rear |
| 11 | Gas pipe | 27 | Bypass Valve retaining nut - front |
| 12 | Flow sensor electrical plug | 28 | Impeller housing |
| 13 | Flow sensor | 29 | Safety discharge valve plastic housing |
| 14 | Heating return pipe | 30 | Retaining clip |
| 15 | Expansion vessel pipe | 31 | Filling Valve |
| 16 | Plate-to-plate heat exchanger | | |

17.5.1. Pump (head only)

- Drain the boiler heating circuit as described in the appropriate chapter "Draining".
- Disconnect the electrical plug (22) from the main board.
- Disconnect the electrical plug from the pump head.
- Remove the four cap head screws (20).
- Carefully remove the pump head (21) together with cable. Do not strain cable.
- Reconnect wiring to new pump head and fit cover.
- Fit the new pump head by repeating the operations in reverse.

17.5.2. Safety discharge valve

- Drain the boiler heating circuit as described in the appropriate chapter "Draining".
- Undo the safety discharge valve union and remove from the pipework .
- Unscrew the safety discharge valve (24).
- Fit new 'O' ring. Refill, vent and pressurise the boiler.

17.5.3. Automatic air vent

- Drain the boiler heating circuit as described in the appropriate chapter "Draining".
- Remove the retaining clip (19).
- Remove the automatic air vent (17).
- Fit the new automatic air vent and 'O' ring ensuring the vent cap is left loose.
- Refill, vent and pressurise the boiler.

17.5.4. Low water pressure sensor

- Drain the boiler hot water circuit as described in the appropriate chapter "Draining".
- Remove the side securing clip(6) and the electrical connection (4).
- Disengage the low water pressure sensor

- After replacing the water pressure sensor open the cold-water isolation valve and slowly open a hot water tap to remove air.

17.5.5. Flow sensor and impeller

- Drain the boiler heating circuit as described in the appropriate chapter "Draining".
- Remove the the electrical connection (12).
- Unclip the flow sensor (13).
- Unscrew the impeller housing (28) and remove the impeller.
- After replacing the impeller, vent and pressurise the boiler.

17.5.6. Bypass

- Drain the boiler heating circuit as described in the appropriate chapter "Draining".
- Remove the retaining clip to remove the bypass screw .
- After replacing the bypass, refill, vent and pressurise the boiler.

17.5.7. Three way valve motor

- Drain the boiler heating circuit as described in the appropriate chapter "Draining".
- Disconnect the electrical plug (1).
- Remove the retaining clip (3).
- Remove the three way valve motor (2).
- Fit new three way valve motor assembly
- Refill, vent and pressurise the boiler.

17.5.8. Plate-to-plate heat exchanger

- Drain the boiler heating and domestic hot water circuits as described in the appropriate chapter "Draining".
- Remove the two securing screws (23).
- Remove the plate-to-plate heat exchanger (16).
- When replacing the plate-to-plate heat exchanger, ensure that the four rubber sealing washers are fitted into the hydroblock.

NOTE: The plate-to-plate heat exchanger only fits one way.

- Refill, vent and pressurise the boiler.

17.6. Combustion block

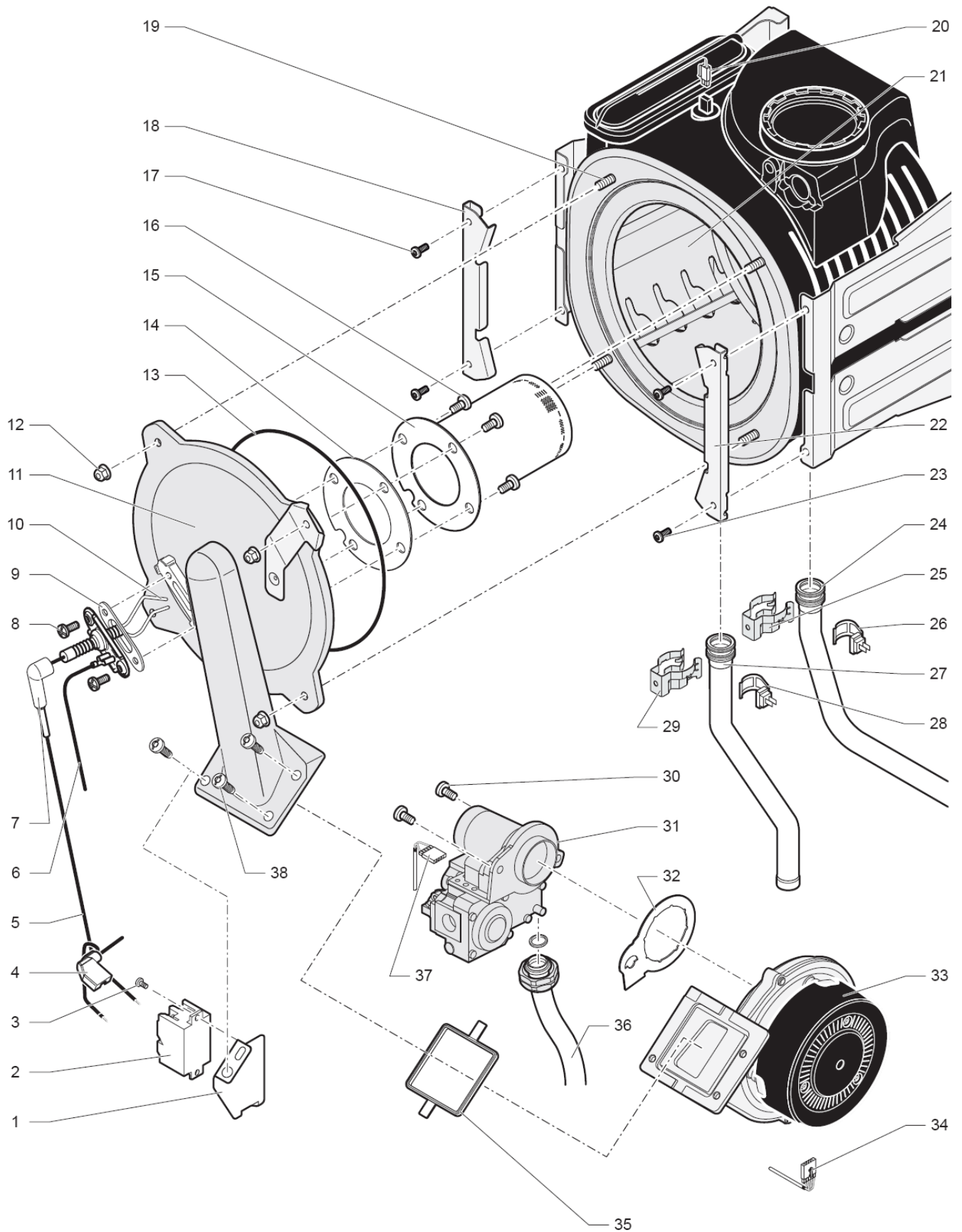

- Legend**
1 Igniter unit retaining bracket
2 Igniter unit
3 Igniter unit retaining screw

4 Igniter unit electrical connector
 5 Electrode / igniter unit connection cable
 6 Earth cable
 7 Spark electrode cap
 8 Spark electrode retaining screw
 9 Spark electrode gasket
 10 Spark electrode
 11 Combustion burner door assembly
 12 Combustion burner door assembly - nut
 13 Combustion burner door assembly - gasket
 14 Burner gasket
 15 Burner
 16 Burner retaining screw
 17 Heat exchanger retaining screw
 18 Heat exchanger retaining bracket
 19 Burner gate retaining screw
 20 Thermal fuse connection
 21 Heat exchanger
 22 Heat exchanger retaining bracket
 23 Heat exchanger retaining screw
 24 Heating return pipe
 25 Heating return pipe retaining clip
 26 Return heating temperature sensor
 27 Heating flow pipe
 28 Flow heating temperature sensor
 29 Heating flow pipe retaining clip
 30 Gas valve retaining screw
 31 Gas valve
 32 Gas valve gasket
 33 Fan
 34 Fan electrical connection
 35 Fan/burner gasket
 36 Gas pipe
 37 Gas valve electrical connection
 38 Fan retaining screw

17.6.1. Spark electrode

- Disconnect the electrode cap (7) and the earthing cable (6).
- Remove the 2 spark electrode retaining screws (8).
- Carefully remove the electrode (10) from the combustion chamber.
- Remove the gasket (9).
- Check that the distance between the 2 electrodes is between 3.5 and 4.5 mm.
- Install the electrode and a new gasket.

17.6.2. Igniter unit

- Remove the ignition connections (2).
- Remove electrical connections (4).
- Loosen the screws (3) located on the igniter unit (2).
- Remove the igniter unit (2).

17.6.3. Removing the combustion /burner door assembly

Warning: *The gasket (13) must be replaced each time the combustion /burner door assembly is removed.*



- Disconnect the spark electrode cap (7) from the igniter unit.
- Disconnect the gas supply pipe (36) at the gas valve.
- Remove the electrical connectors from the gas valve (37) and the fan (34).
- Remove the retaining screw of the silencer.
- Loosen the 4 nuts (12).
- Remove the combustion/burner door assembly from the heat exchanger (11).
- The studs (19) must not be damaged. If damaged you will need to replace the heat exchanger.
- The combustion/burner door assembly insulation should be inspected and replaced if damaged.

17.6.4. Burner

- Remove the 3 burner retaining screws (16).
- Remove the burner (15) and the gasket (14).
- Fit the new burner and the new gasket.

17.6.5. Heat exchanger



There will be water in the heat exchanger.

Carefully ease heat exchanger out.

- Drain the boiler heating and hot water circuits as described in the appropriate chapter "Draining".
- Remove the flue connection.
- Undo the two screws located on the top of each side panel.
- Remove the thermal fuse connector (20).
- Remove the 2 heating pipe retaining clips (25) and (29).
- Release the heating pipes (24) and (27) from the heat exchanger.
- Release the condensate trap pipe from the heat exchanger.

- Remove the combustion/burner door assembly (11) referring to chapter "Removing the combustion/burner door assembly".
- Unscrew the 4 retaining screws (17) and (23) and remove the 2 retaining plates (18) and (22) from the heat exchanger.
- Pull the heat exchanger towards you to extract it from its 2 side rails.

17.6.6. Re-assembling the burner group

- Place the burner assembly on the heat exchanger (21).
- Progressively tighten the 4 nuts (12) in an alternate order.
- Reassemble the silencer.
- Connect the gas pipe (36) with a new gasket to the burner group.
- Connect the spark electrode connector (5) to the igniter unit.
- Connect the connector to the gas valve (37) and the fan (34).
- Open the appliance's gas input.
- Check the tightness of the gas connection.

17.6.7. Heating Flow Thermistor

- Remove the electrical connections from the thermistor (28).
- Remove the retaining clip from the flow pipe (27).



When reconnecting, the polarity of the wiring to thermistors is not important.

17.6.8. Heating Return Thermistor

- Remove the electrical connections from the thermistor (26).
- Remove the retaining clip from the return pipe (24).
 - ▣ *When reconnecting, the polarity of the wiring to thermistors is not important.*
 - ▣

17.6.9. Gas valve

- Remove the burner door (11) referring to chapter "Dismantling the burner door".
- Remove the two gas valve retaining screws (30).
- Remove the gas valve (31) and the gasket (32).
- Fit the new gas valve and the new gasket by repeating the operations in reverse.
- After assembly test for gas tightness and purge in accordance with the current issue of BS6891 or in IE, the current edition of I.S.813 "Domestic Gas Installations".
- Check the combustion CO₂.

17.6.10. Fan

- Remove the burner door (11) referring to chapter "Dismantling the burner door".
- Remove the gas valve (31) (see previous paragraph).
- Loosen the 3 screws (38) located on the burner door (11).
- Remove the fan (33) and the gasket (35).
- Fit the new gasket (35).
- Screw the new fan to the burner door (11).
- After assembly test for gas tightness and purge in accordance with the current issue of BS6891 or in IE, the current edition of I.S.813 "Domestic Gas Installations".

17.7. Condensate trap



Warning: condensate is mildly acidic. Wear protective gloves.

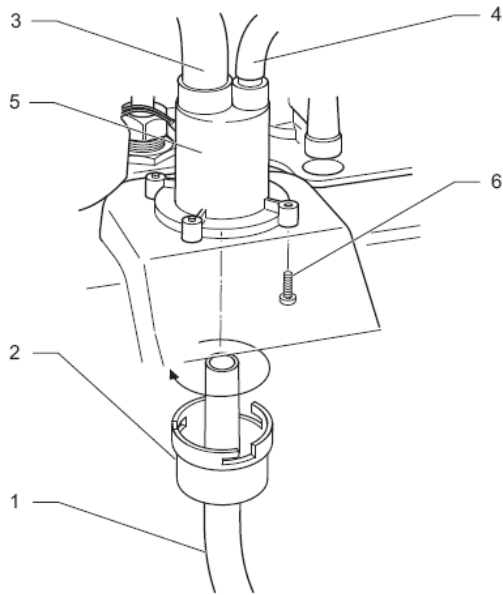

Key
 1 Condensate outlet
 2 Condensate reservoir
 3 Condensate trap
 4 Condensate retaining screw

- Place a container under the condensate trap (3).
- Remove the condensate from the reservoir (2).
- Disconnect the condensation discharge (1).

The condensate trap will contain water, lift taking care not to spill the water.

- Remove the condensate trap (2) using the retaining screws (4).
- **IMPORTANT:** Partially fill the condensate trap with water before replacing.

17.8. PCB



When replacing the board refer to instructions supplied with the spare part.

Key
 1 Main board
 2 Retainings clips
 3 Electrical connections
 4 Control box

- Disconnect the electrical connections (3) from the main PCB, noting their positions.
- Ease back the two PCB retaining clips (2) and withdraw the PCB (1) from the retaining lugs.
- When refitting, ensure leads are not trapped.

17.8.2. 2A Fuse Rating

- For access, refer to chapter "Main PCB".
- The fuse is located at top right hand side of the PCB, see chapter "Electrical connection ► Wiring diagram".

17.8.3. User interface PCB

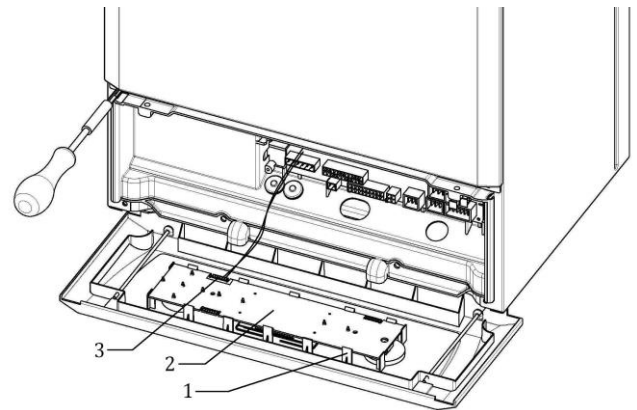

Key
 1 Retainings clips
 2 User interface PCB
 3 Electrical connections

- Ease back the PCB retaining clips (1) and withdraw the user interface PCB (2) from the retaining lugs.
- Remove the electrical connections (3) to the PCB.
- When refitting the user interface, ensure the leads are not trapped.

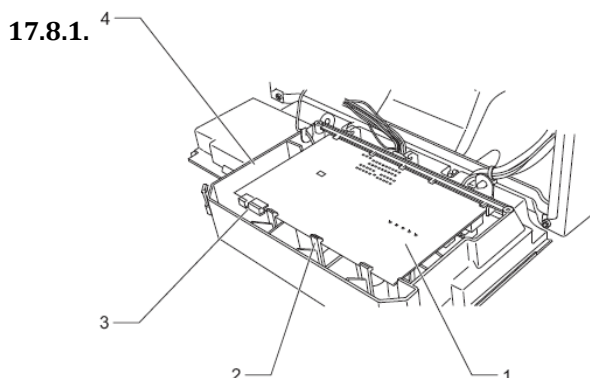

17.8.4. Mains supply cable



The mains supply cable must be replaced by a lified and competent electrician.

- If the main supply cable is damaged, replace it referring to the chapter "Electrical connection".

18. Spare parts

In order to guarantee the safe and prolonged life of the product, manufacturers genuine spare parts must be used.



This appliance displays a CE Mark of conformity.

Only use the manufacturer's genuine, new spare parts.

- Ensure that spare parts are correctly mounted in the right position and direction. After fitting any spare part or servicing, the appliance must be tested for its safe operation.

Manual Handling

IMPORTANT

With regards to the Manual Handling Operations, 1992 Regulations, the following lift operation exceeds the recommended weight for a one man lift.

General recommendations when handling

Clear the route before attempting the lift.

Ensure safe lifting techniques are used – keep back straight – bend using legs. Keep load as close to body as possible. Do not twist – reposition feet instead. If 2 persons performing lift, ensure co-ordinated movements during lift. Avoid upper body/top heavy bending - do not lean forward/sideways. Recommend wear suitable cut resistant gloves with good grip to protect against sharp edges and ensure good grip. Always use assistance if required.

Removal of carton from delivery van

Recommend 2 person lift or 1 person with use of sack truck. If 1 person is performing lift, straddle the load, tilt and place carton into position on truck. Recommend secure appliance onto truck with suitable straps. Ensure safe lifting techniques are used – keep back straight – bend using legs. Keep load as close to body as possible. If 2 persons performing lift, ensure co-ordinated movements during lift. Always use assistance if required.

Carriage of carton from point of delivery to point of installation – ground floor.

Recommend 2 person lift or 1 person with use of sack truck. If 1 person is performing lift, straddle the load, tilt and place carton into position on truck. Recommend secure appliance onto truck with suitable straps. Ensure safe lifting techniques are used – keep back straight – bend using legs. Keep load as close to body as possible. If 2 persons performing lift, ensure co-ordinated movements during lift. Clear the route before attempting the lift. If removing boiler from truck straddle the load and tilt forwards to facilitate secure grip. Ensure safe lifting techniques are used – keep back straight – bend using legs. Do not twist – reposition feet instead. Take care to avoid trip hazards, slippery or wet surfaces and when climbing steps and stairs. Always use assistance if required.

Carriage of carton from point of delivery to point of installation – first or higher floor, cellar.

Recommend 2-person lift or 1 person with use of sack truck. If 1 person is performing lift, straddle the load, tilt and place carton into position on truck. Recommend secure appliance onto truck with suitable straps. Ensure safe lifting techniques are used – keep back straight – bend using legs. Keep load as close to body as possible. If 2 persons performing lift, ensure co-ordinated movements during lift. Avoid upper body/top heavy bending - do not lean forward/sideways. Clear the route before attempting the lift. If removing boiler from truck straddle the load and tilt forwards to facilitate secure grip. Ensure safe lifting techniques are used – keep back straight – bend using legs. Do not twist – reposition feet instead. Take care to avoid trip hazards, slippery or wet surfaces and when climbing steps and stairs. Always use assistance if required.

Carriage of carton from point of delivery to point of installation – roofspace.

Recommend 2-person lift. Ensure co-ordinated movements during lift. Avoid upper body/top heavy bending - do not lean forward/sideways. Clear the route before attempting the lift. Take care to avoid trip hazards, slippery or wet surfaces and when climbing steps and stairs. When transferring appliance into roofspace, recommend 1 person to be in roofspace to receive the appliance and other person to be below to pass up and support appliance. Ensure safe lifting techniques are used – keep back straight – bend using legs. Keep load as close to body as possible. Always use assistance if required. It is assumed safe access, flooring and adequate lighting are provided in the roof space. It is recommended a risk assessment of the roof space area be carried out before moving the appliance into the area to take into account access, stability of flooring, lighting and other factors, and appropriate measures taken.

Unpacking of appliance from carton.

Recommend 2 persons unpack appliance from carton. Always keep working area clear. Cut the carton straps, lift carton up and slide over polystyrene end packs. Remove top polystyrene pack with fittings.

Positioning of Appliance for Final Installation – no obstructions.

Recommend 2 persons lift appliance to position into place. Fit bracket securely onto wall before lifting appliance into position. Obtain firm grip on front and sides of appliance, lift upwards, ensure stable balance achieved and lift upwards to position in place on bracket. Ensure safe lifting techniques are used – keep back straight – bend using legs - when lifting load from floor level. Do not twist – reposition feet instead. Keep boiler as close as possible to body throughout lift to minimise strain on

back. Ensure co-ordinated movements to ensure equal spread of weight of load. Always use assistance if required. Recommend wear suitable cut resistant gloves with good grip to protect against sharp edges and ensure good grip when handling appliance.

Positioning of Appliance for Final Installation – above worktop, foreseeable obstructions etc.

Recommend 2 persons lift appliance to position into place. Fit bracket securely onto wall before lifting appliance into position. Obtain firm grip on front and sides of appliance, lift upwards, onto worktop if practicable. Ensure stable balance achieved and lift upwards to position in place on bracket. If 2 persons positioning onto bracket obtain firm grip at front and sides/base of boiler. Ensure co-ordinated movements during 2 person lifts to ensure equal spread of weight of load. Ensure safe lifting techniques are used – keep back straight – bend using legs - when lifting load from floor level. Do not twist – reposition feet instead. Keep boiler as close as possible to body throughout lift to minimise strain on back. Avoid upper body/top heavy bending - do not lean forward/sideways. Always use assistance if required. Recommend wear suitable cut resistant gloves with good grip to protect against sharp edges and ensure good grip when handling appliance.

Positioning of Appliance for Final Installation – within compartment etc. restricting installation.

Recommend 2 persons lift appliance to position into place, space permitting. Fit bracket securely onto wall before lifting appliance into position. Obtain firm grip on front and sides of appliance, lift upwards, onto worktop if practicable. Ensure stable balance achieved and lift upwards to drop into place onto bracket. If 2 persons positioning onto bracket obtain firm grip at front and sides/base of boiler. Ensure co-ordinated movements during 2 person lifts to ensure equal spread of weight of load. If 1 person positioning onto bracket recommend obtain firm grip supporting base of boiler. Ensure safe lifting techniques are used – keep back straight – bend using legs - when lifting load from floor level. Do not twist – reposition feet instead. Keep boiler as close as possible to body throughout lift to minimise strain on back. Always use assistance if required. Recommend wear suitable cut resistant gloves with good grip to protect against sharp edges and ensure good grip when handling appliance.,

Positioning of Appliance for Final Installation – in roof space restricting installation.

Recommend 2 persons lift appliance to position into place, space permitting. Fit bracket securely onto wall before lifting appliance into position. Obtain firm grip on front and sides of appliance, lift upwards, ensure stable balance achieved and lift upwards to drop into place onto bracket. If 2 persons positioning onto bracket obtain firm grip at front and sides/base of boiler. Ensure co-ordinated movements during 2 person lifts to ensure equal spread of weight of load. If 1 person positioning onto bracket recommend obtain firm grip supporting base of boiler. Ensure safe lifting techniques are used - keep back straight – bend using legs - when lifting load from floor level. Do not twist – reposition feet instead. Keep boiler as close as possible to body throughout lift to minimise strain on back. Always use assistance if required. Recommend wear suitable cut resistant gloves with good grip to protect against sharp edges and ensure good grip when handling appliance. It is recommended a risk assessment of the roof space area be carried out before moving the appliance into the area to take into account access, stability of flooring, lighting and other factors, and appropriate measures taken.